

# Lembar data produk

Spesifikasi



## variable speed drive ATV32 - 15 kW - 400 V - 3 phase - with heat sink

ATV32HD15N4

⚠ **Telah dihentikan pada:** 09 September 2020

⚠ **Berakhirnya layanan pada:** 31 Desember 2018

⚠ **Dihentikan**

### Main

Range of product	Altivar 32
Product or component type	Variable speed drive
Product destination	Synchronous motors Asynchronous motors
Product specific application	Complex machines
Function available	-
Assembly style	With heat sink
Component name	ATV32
EMC filter	Class C2 EMC filter integrated
Network number of phases	3 phases
[Us] rated supply voltage	380...500 V - 15...10 %
Supply voltage limits	323...550 V
Supply frequency	50...60 Hz - 5...5 %
Network frequency	47.5...63 Hz
Motor power kW	15 kW at 380...480 V
Motor power hp	20 hp at 380...480 V

### Complementary

Line current	33.3 A for 500 V 3 phases 15 kW / 20 hp 47.3 A for 380 V 3 phases 15 kW / 20 hp
Apparent power	41 kVA at 500 V 3 phases 15 kW / 20 hp
Prospective line I <sub>sc</sub>	22 kA for 3 phases
Nominal output current	33 A at 4 kHz 500 V 15 kW / 20 hp
Maximum transient current	49.5 A for 60 s 15 kW / 20 hp
Output frequency	0.0005...0.599 kHz
Nominal switching frequency	4 kHz
Switching frequency	2...16 kHz adjustable
Speed range	1...100 for asynchronous motor in open-loop mode
Speed accuracy	+/- 10 % of nominal slip 0.2 T <sub>n</sub> to T <sub>n</sub>

<b>Torque accuracy</b>	+/- 15 %
<b>Transient overtorque</b>	170...200 %
<b>Braking torque</b>	<= 170 % with braking resistor
<b>Asynchronous motor control profile</b>	Voltage/frequency ratio, 2 points Flux vector control without sensor - Energy Saving, NoLoad law Flux vector control without sensor, standard Voltage/frequency ratio, 5 points Voltage/frequency ratio - Energy Saving, quadratic U/f
<b>Synchronous motor control profile</b>	Vector control without sensor
<b>Regulation loop</b>	Adjustable PID regulator
<b>Motor slip compensation</b>	Not available in voltage/frequency ratio (2 or 5 points) Automatic whatever the load Adjustable 0...300 %
<b>Local signalling</b>	1 LED red for drive voltage 1 LED green for CANopen run 1 LED red for CANopen error 1 LED red for drive fault
<b>Output voltage</b>	<= power supply voltage
<b>Noise level</b>	43 dB conforming to 86/188/EEC
<b>Insulation</b>	Electrical between power and control
<b>Electrical connection</b>	Screw terminal, clamping capacity: 16 mm <sup>2</sup> , AWG 6 (power supply) Screw terminal, clamping capacity: 0.5...1.5 mm <sup>2</sup> , AWG 18...AWG 14 (control) Removable screw terminals, clamping capacity: 6...16 mm <sup>2</sup> , AWG 8...AWG 6 (motor/braking resistor)
<b>Tightening torque</b>	0.5 N.m, 4.4 lb/ft (control) 1.2 N.m, 10.6 lb/ft (motor/braking resistor) 1.2 N.m, 10.6 lb/ft (power supply)
<b>Supply</b>	Internal supply for reference potentiometer (1 to 10 kOhm): 10.5 V DC +/- 5 %, <10 mA, protection type: overload and short-circuit protection
<b>Analogue input number</b>	3
<b>Analogue input type</b>	AI1 voltage: 0...10 V DC, impedance: 30000 Ohm, resolution 10 bits AI2 bipolar differential voltage: +/- 10 V DC, impedance: 30000 Ohm, resolution 10 bits AI3 current: 0...20 mA (or 4-20 mA, x-20 mA, 20-x mA or other patterns by configuration), impedance: 250 Ohm, resolution 10 bits
<b>Sampling duration</b>	2 ms (AI1, AI2, AI3) - analog input(s) 2 ms (AO1) - analog input(s)
<b>Response time</b>	LI1...LI6 8 ms, tolerance +/- 0.7 ms for logic output(s) R1A, R1B, R1C 2 ms for relay output(s) R2A, R2C 2 ms for relay output(s)
<b>Accuracy</b>	+/- 0.2 % (AI1, AI2, AI3) for a temperature of -10...60 °C +/- 0.5 % (AI1, AI2, AI3) for a temperature of 25 °C +/- 1 % (AO1) for a temperature of 25 °C +/- 2 % (AO1) for a temperature of -10...60 °C
<b>Linearity error</b>	+/- 0.2...0.5 % of maximum value (AI1, AI2, AI3) +/- 0.3 % (AO1)
<b>Analogue output number</b>	1
<b>Analogue output type</b>	AO1 software-configurable current 0...20 mA, impedance: 800 Ohm, resolution 10 bits AO1 software-configurable voltage 0...10 V, impedance: 470 Ohm, resolution 10 bits
<b>Discrete output number</b>	3
<b>Discrete output type</b>	Configurable relay logic: (R1A, R1B, R1C) NO/NC - 100000 cycles Configurable relay logic: (R2A, R2B) NO - 100000 cycles Logic: (LO)
<b>Minimum switching current</b>	5 mA at 24 V DC for configurable relay logic
<b>Maximum switching current</b>	R1: 3 A at 250 V AC resistive load, cos phi = 1 R1: 4 A at 30 V DC resistive load, cos phi = 1 R1, R2: 2 A at 250 V AC inductive load, cos phi = 0.4 R1, R2: 2 A at 30 V DC inductive load, cos phi = 0.4 R2: 5 A at 250 V AC resistive load, cos phi = 1 R2: 5 A at 30 V DC resistive load, cos phi = 1
<b>Discrete input number</b>	7
<b>Discrete input type</b>	Programmable (sink/source) (LI1...LI4)24...30 V DC, with level 1 PLC Programmable as pulse input 20 kpps (LI5)24...30 V DC, with level 1 PLC

Switch-configurable PTC probe (LI6)24...30 V DC  
 Safe torque off (STO)24...30 V DC - 1500 Ohm

<b>Discrete input logic</b>	Negative logic (sink) (LI1...LI6), > 19 V (state 0), < 13 V (state 1) Positive logic (source) (LI1...LI6), < 5 V (state 0), > 11 V (state 1)
<b>Acceleration and deceleration ramps</b>	Deceleration ramp automatic stop DC injection Deceleration ramp adaptation U S Linear Ramp switching CUS
<b>Braking to standstill</b>	By DC injection
<b>Protection type</b>	Input phase breaks: drive Overcurrent between output phases and earth: drive Overheating protection: drive Short-circuit between motor phases: drive Thermal protection: drive
<b>Communication port protocol</b>	CANopen Modbus
<b>Connector type</b>	1 RJ45 (on front face) for Modbus/CANopen
<b>Physical interface</b>	2-wire RS 485 for Modbus
<b>Transmission frame</b>	RTU for Modbus
<b>Type of polarization</b>	No impedance for Modbus
<b>Number of addresses</b>	1...127 for CANopen 1...247 for Modbus
<b>Method of access</b>	Slave CANopen
<b>Electromagnetic compatibility</b>	1.2/50 µs - 8/20 µs surge immunity test, level 3 conforming to IEC 61000-4-5 Conducted radio-frequency immunity test, level 3 conforming to IEC 61000-4-6 Electrical fast transient/burst immunity test, level 4 conforming to IEC 61000-4-4 Electrostatic discharge immunity test, level 3 conforming to IEC 61000-4-2 Radiated radio-frequency electromagnetic field immunity test, level 3 conforming to IEC 61000-4-3 Voltage dips and interruptions immunity test conforming to IEC 61000-4-11
<b>Width</b>	180 mm
<b>Height</b>	404 mm
<b>Depth</b>	232 mm
<b>Net weight</b>	8.8 kg
<b>Option card</b>	Communication card for CANopen daisy chain Communication card for CANopen open style Communication card for DeviceNet Communication card for EtherNet/IP Communication card for Profibus DP V1
<b>Functionality</b>	Mid
<b>Specific application</b>	Other applications

## Environment

<b>Standards</b>	EN 55011 class A group 1 EN/IEC 61800-3 EN 61800-3 environments 2 category C2 EN/IEC 61800-5-1 EN 61800-3 environments 1 category C2
<b>Product certifications</b>	UL NOM 117 CSA C-Tick GOST
<b>Marking</b>	CE
<b>Pollution degree</b>	2 conforming to EN/IEC 61800-5-1
<b>IP degree of protection</b>	IP20 conforming to EN/IEC 61800-5-1
<b>Vibration resistance</b>	1 gn (f = 13...200 Hz) conforming to EN/IEC 60068-2-6 1.5 mm peak to peak (f = 3...13 Hz) conforming to EN/IEC 60068-2-6
<b>Shock resistance</b>	15 gn for 11 ms conforming to EN/IEC 60068-2-27

<b>Relative humidity</b>	5...95 % without condensation conforming to IEC 60068-2-3 5...95 % without dripping water conforming to IEC 60068-2-3
<b>Ambient air temperature for operation</b>	-10...50 °C without derating 50...60 °C with derating factor
<b>Ambient air temperature for storage</b>	-25...70 °C
<b>Operating altitude</b>	<= 1000 m without derating 1000...3000 m with current derating 1 % per 100 m
<b>Operating position</b>	Vertical +/- 10 degree

## Contractual warranty

<b>Warranty</b>	18 months
-----------------	-----------

Size D

Dimensions

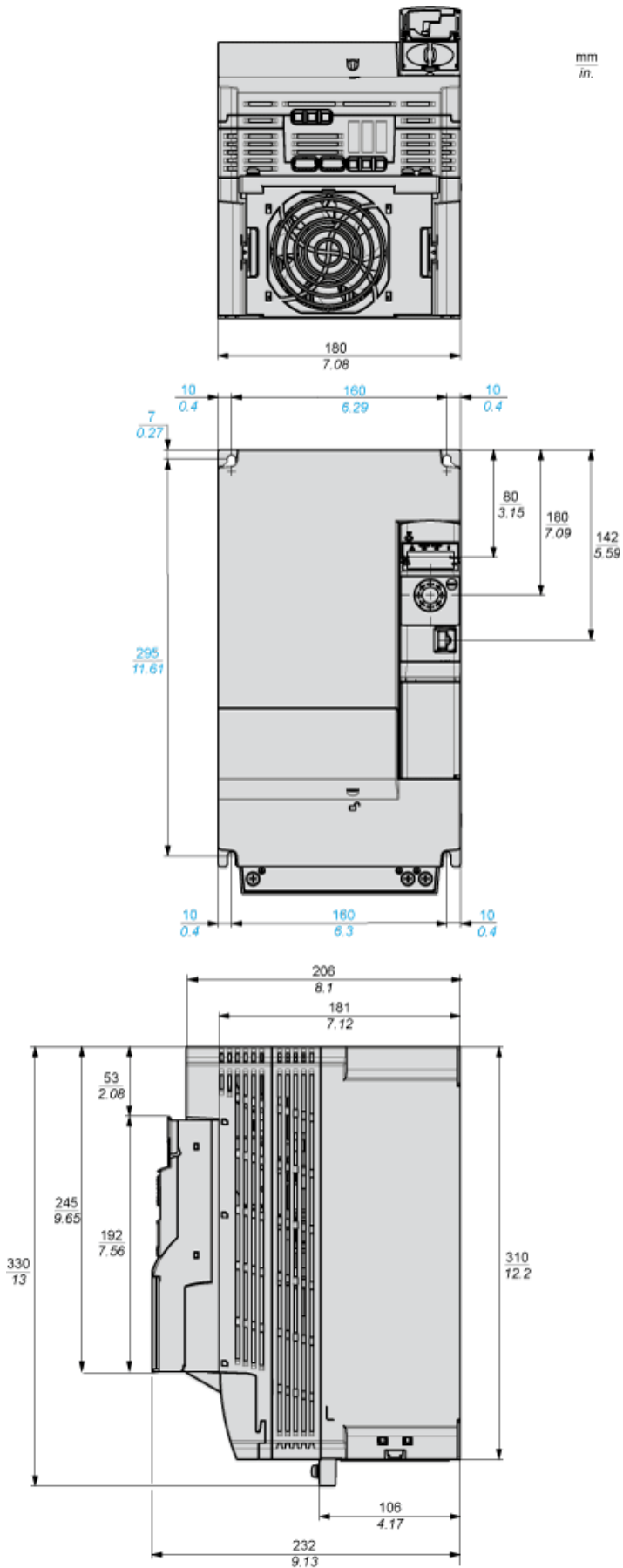

Size D - with EMC plate

Dimensions

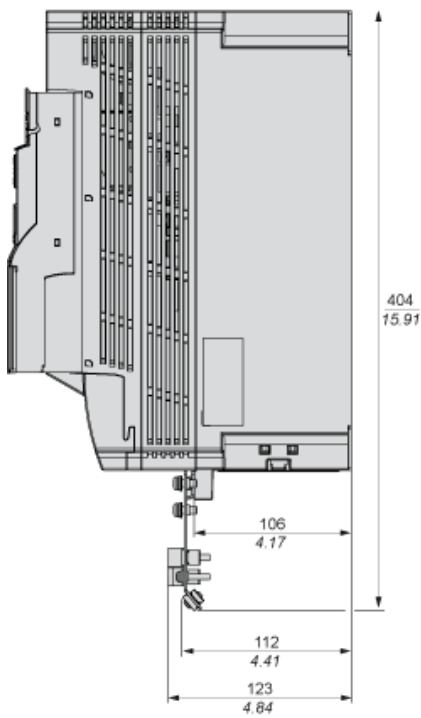
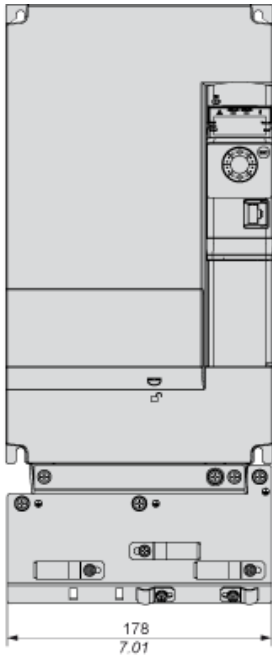

Mounting and Clearance

---

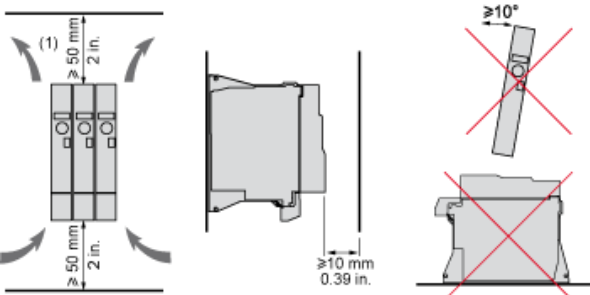

(1) Minimum value corresponding to thermal constraints.

**Connection Diagrams**

**Single or Three-phase Power Supply - Diagram with Line Contactor**

Connection diagrams conforming to standards EN 954-1 category 1 and IEC/EN 61508 capacity SIL1, stopping category 0 in accordance with standard IEC/EN 60204-1.

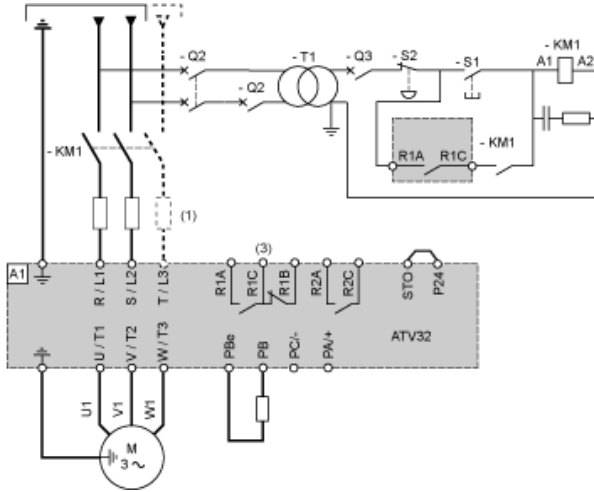

- (1) Line choke (if used)
- (3) Fault relay contacts, for remote signaling of drive status

**Single or Three-phase Power Supply - Diagram with Switch Disconnect**

Connection diagrams conforming to standards EN 954-1 category 1 and IEC/EN 61508 capacity SIL1, stopping category 0 in accordance with standard IEC/EN 60204-1.

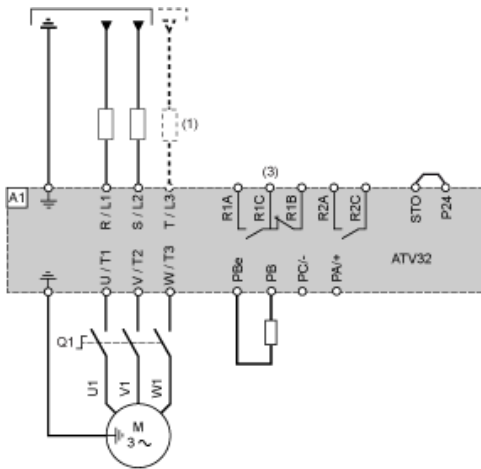

- (1) Line choke (if used)
- (3) Fault relay contacts, for remote signaling of drive status

**Diagram with Preventa Safety Module (Safe Torque Off Function)**

Connection diagrams conforming to standards EN 954-1 category 3 and IEC/EN 61508 capacity SIL2, stopping category 0 in accordance with standard IEC/EN 60204-1.

When the emergency stop is activated, the drive power supply is cut immediately and the motor stops in freewheel, according to category 0 of standard IEC/EN 60204-1.

A contact on the Preventa XPS AC module must be inserted in the brake control circuit to engage it safely when the STO (Safe Torque Off) safety function is activated.



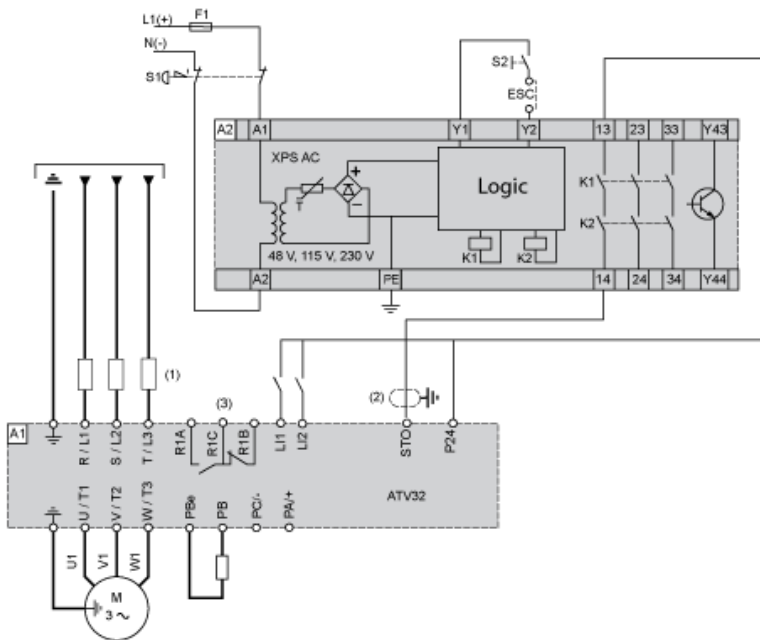

- (1) Line choke (if used)
- (2) It is essential to connect the shielding to the ground.
- (3) Fault relay contacts, for remote signaling of drive status

The STO safety function integrated into the product can be used to implement an "EMERGENCY STOP" (IEC 60204-1) for category 0 stops. With an additional, approved EMERGENCY STOP module, it is also possible to implement category 1 stops.

#### STO function

The STO safety function is triggered via 2 redundant inputs. The circuits of the two inputs must be separate so that there are always two channels. The switching process must be simultaneous for both inputs (offset < 1 s).

The power stage is disabled and an error message is generated. The motor can no longer generate torque and coasts down without braking. A restart is possible after resetting the error message with a "Fault Reset".

The power stage is disabled and an error message is generated if only one of the two inputs is switched off or if the time offset is too great. This error message can only be reset by switching off the product.

#### Diagram without Preventa Safety Module

Connection diagrams conforming to standards EN 954-1 category 2 and IEC/EN 61508 capacity SIL1, stopping category 0 in accordance with standard IEC/EN 60204-1.

The connection diagram below is suitable for use with machines with a short freewheel stop time (machines with low inertia or high resistive torque).

When the emergency stop is activated, the drive power supply is cut immediately and the motor stops in freewheel, according to category 0 of standard IEC/EN 60204-1.

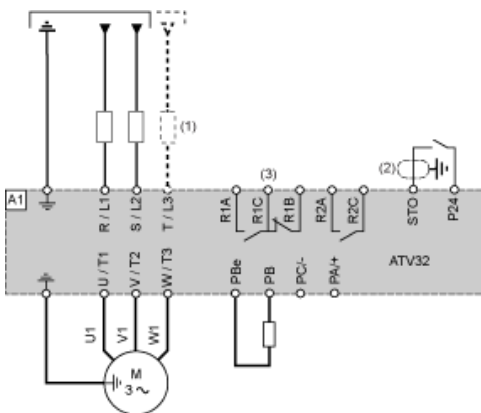

- (1) Line choke (if used)
- (2) It is essential to connect the shielding to the ground.
- (3) Fault relay contacts, for remote signaling of drive status

The STO safety function integrated into the product can be used to implement an "EMERGENCY STOP" (IEC 60204-1) for category 0 stops.

## Control Connection Diagram in Source Mode

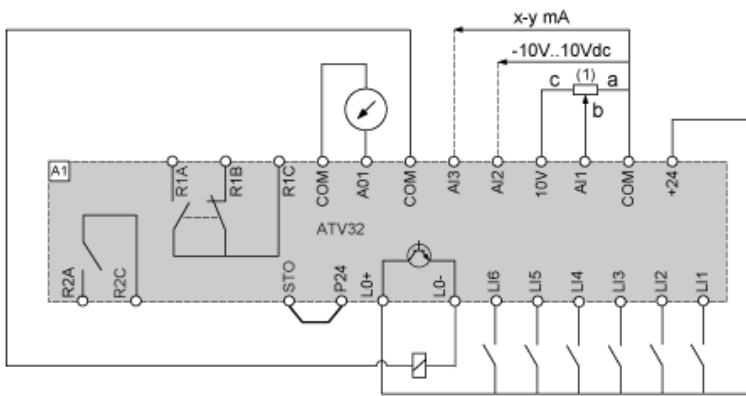

- (1) Reference potentiometer SZ1RV1202 (2.2 k $\Omega$ ) or similar (10 k $\Omega$  maximum)

Derating Curves

Derating curve for the nominal drive current ( $I_n$ ) as a function of temperature and switching frequency.

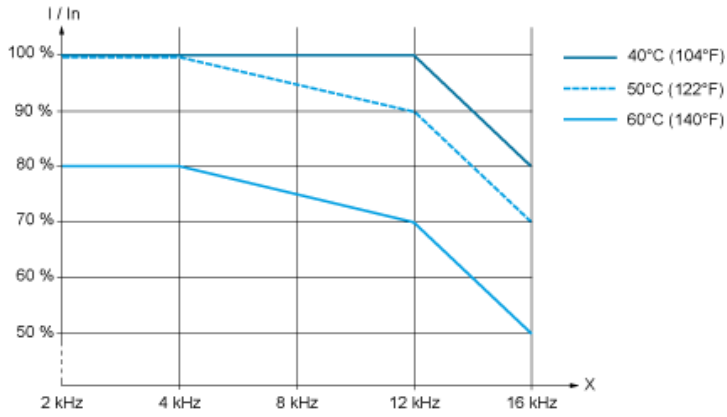

X Switching frequency

Above 4 kHz, the drive will reduce the switching frequency automatically in the event of an excessive temperature rise.

**Sink / Source Switch Configuration (SW1)**

The logic input switch (SW1) is used to adapt the operation of the logic inputs to the technology of the programmable controller outputs.  
 Switch SW1 set to "Source" position

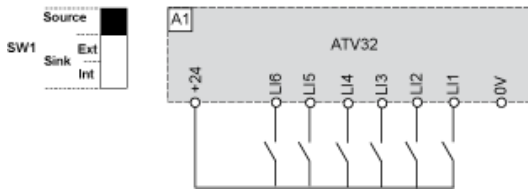

Switch SW1 set to "Source" position and use of an external power supply for the LIs

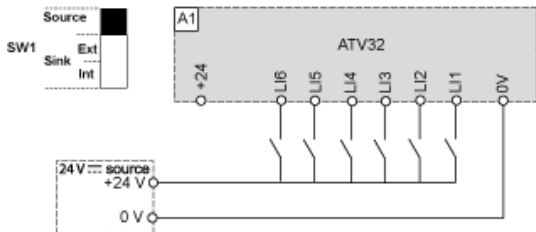

Switch SW1 set to "Sink Int" position

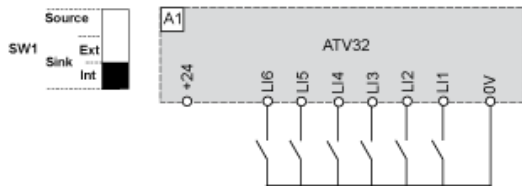

Switch SW1 set to "Sink Ext" position

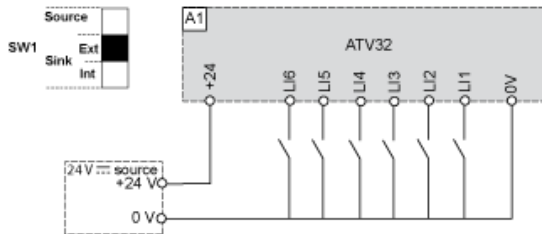

**Penggantian yang disarankan**

ATV32HD15N4 is replaced by:

1x



variable speed drive, ATV320, 15 kW, 380...500 V, 3 phases, book  
 ATV320D15N4B